



AMERICAN SPECIALTIES, INC.

441 Saw Mill River Road, Yonkers, NY 10701 (914) 476-9000

MODEL No: 0180

ISSUED: 9-98

REVISED: 6-99

SURFACE MOUNTED SENSOR HAND DRYER (pg 1/2)

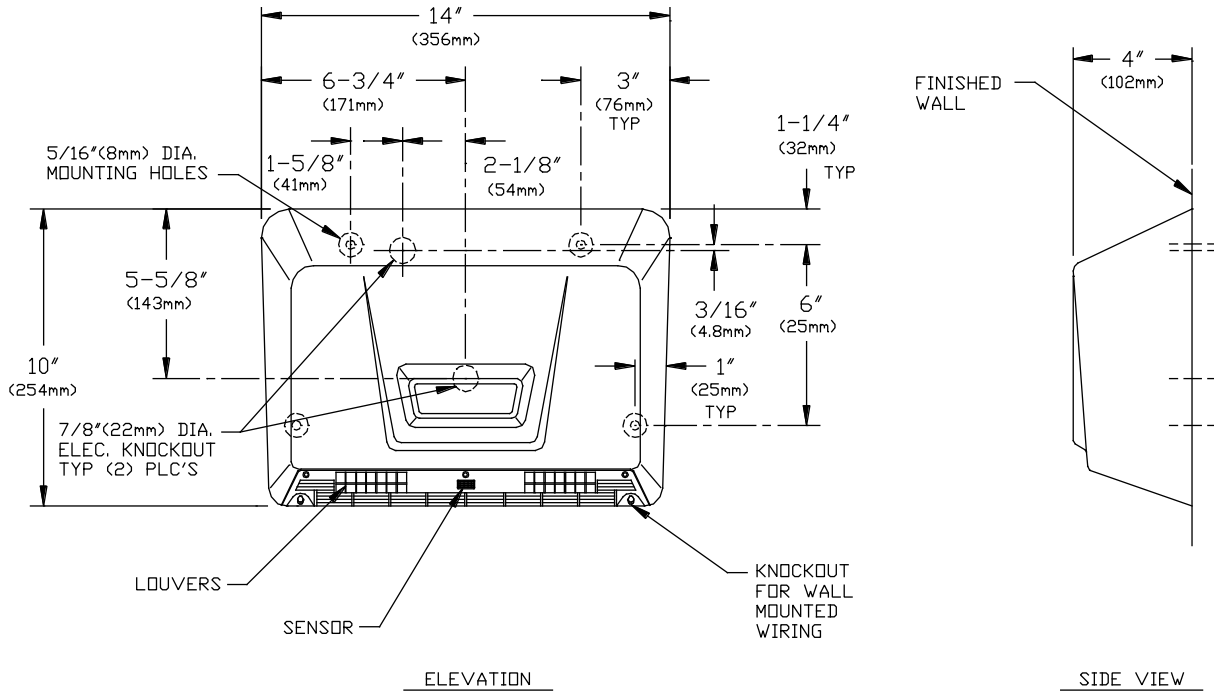

SPECIFICATION

Surface Mounted ADAAG Compliant Hand Dryer with heavy-duty seamless formed steel cover and porcelain enamel finish, or optional stainless steel cover, shall operate automatically from IR sensor that shall activate dryer when hands are placed in sensor zone and shall turn off when hands are removed from sensor zone. Motor and dual heating elements shall have internal resetting automatic thermal protection. Unit shall develop 183 CFM of heated air and shall provide drying time of less than 25 seconds. Cover shall be fabricated of one-piece, 16 gauge steel, 1/16" (1.5mm) thick, and shall have all exposed surfaces finished with acid, chip and scratch resistant porcelain enamel. Dual fixed air vanes shall be heavy-duty, rust proof and highly tamper resistant. Air intake slots shall not allow access to internal parts. Back plate shall be furnished with vibration isolating mounting bushings. Circuitry shall have self-adjusting time-out and fail-safe off protection controlled by a microprocessor that shall detect and reject false signals and shall automatically self-calibrate to provide uniform sensitivity over its entire lifespan. The infra red sensor shall be protected by a heavy-duty polycarbonate lens frequency match-tinted to filter out ambient light. Entire unit shall be internally electrically grounded. Dryer shall be UL , CE and CSA listed. Dryer shall be splashproof as tested by NEMKO and CSA/NRTL. All component parts are warranted to be free of defects in material and workmanship for a period of ten (10) years .

Surface Mounted Sensor Hand Dryer shall be Model N° 0180 of American Specialties, Inc., 441 Saw Mill River Road, Yonkers, NY 10701-4913

INSTALLATION

Unit is surface mounted on wall with four (4) 1/4" screws or bolts (not supplied) through bushings in a corrosion protected formed heavy steel back plate. Electrical service is supplied and connected (by others) prior to installing cover. Cover is secured to back plate with recessed, flat-head, tamper resistant, pin-hex bolts (supplied). For compliance with ADA Accessibility Guidelines, unit should be installed so that bottom of sensor lens is 54" (1372mm) maximum above finished floor (AFF) if clear floor side reach access is provided or 48" (1219mm) max. AFF if clear floor forward reach access is only provided. For general utility install unit so that sensor lens is 45" to 50" (1143mm to 1270mm) AFF.

OPERATION

Dryer is activated by user placing hands in the sensor zone. Dryer remains active until after hands are removed from sensor zone.

Accessory Specialties

AMERICAN DISPENSER

Desert Ray Products

WATROUS INC.



AMERICAN SPECIALTIES, INC.

441 Saw Mill River Road, Yonkers, NY 10701 (914) 476-9000

MODEL No: 0180

ISSUED: 9-98

REVISED: 6-99

SURFACE MOUNTED SENSOR HAND DRYER (pg 2/2)

RATINGS

MODEL #	TYPE	TIMING	VOLTS	AMPS	WATTS	COLOR*
0180	Hand	Automatic 2 second hold on	100VAC-277VAC 50/60Hz.	20max	2300	White

MOTOR	H/P	RPM	FAN TYPE	CFM	HEATING ELEMENT	OUTPUT
Brush Type	1/4	7500	Dual Inlet Centrifugal	183	2-1000 Watt Nichrome wire with auto reset circuit breaker	143° F ± 5@ 70° ambient room temp

COLOR OPTIONS*

Unit is supplied with white finish unless color option is specified. Specify optional color by adding appropriate code number suffix to standard model number (i.e. 0180-71) and indicate option by circle on correct code in chart. For color chips see the **OPTIONS** Section.

CODE	COLOR	CODE	COLOR	CODE	COLOR
40	Cool Grey	71	Almond	92	Bright Stainless Steel
41	Black	87	Desert Sand	93	Satin Stainless Steel